



CHIPBLASTER B-SERIES HIGH PRESSURE COOLANT

CHIPBLASTER B-SERIES

Small footprint, affordability and easy mobility

CHIPBLASTER B-Series high pressure coolant systems are fixed rate medium and high pressure units. These units are compact and economical with limited options.

| | B-30/35 | B-30/70 | B-30/70H |
|--------------------------------|------------------------------|---------|------------|
| Volumes | 30 Liters Per Minute (8 GPM) | | |
| Pressures | 35 bar | 70 bar | 70 bar |
| Standard Coolant Tank Capacity | N/A | N/A | 190 liters |



YOUR ONE-STOP-SHOP
FOR MACHINE-TOOL PERIPHERALS



CHIPBLASTER B-SERIES HIGH PRESSURE COOLANT

B-30/35



CHIPBLASTER B-30/35 is a single M code controlled, fixed rate medium pressure coolant system. A single pleated, 10-micron filter, automatic overload system, and dirty filter alarm circuit provide a safe machining process that helps prevent damage to the machine-tool, workpiece and tooling. Ideal for machine-tools up to 15 kW (20 hp) and 40 taper mills. The built-in casters make it easy to move for maintenance.

| Model | Flow | Pressure | Outlets | Tank | Options | Hydracell | Dimensions |
|---------|----------------------|----------|---------|------|---------|-----------|-----------------------|
| B-30/35 | 30 liters per minute | 35 bar | 1 | N/A | N/A | N/A | 0.79m x 0.86m x 0.69m |

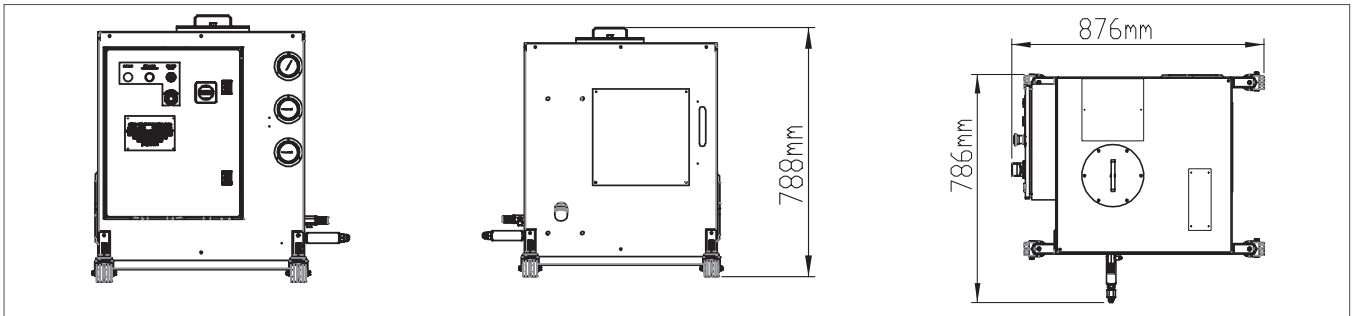

B-30/70



CHIPBLASTER B-30/70 is a single M code controlled, fixed rate high pressure coolant system. The unit has 2 pleated, 10-micron filters that can be manually switched as needed, automatic overload system, and dirty filter alarm circuit. These features provide a safe machining process that helps prevent damage to the machine-tool, workpiece and tooling. Ideal for machine-tools up to 15 kW (20 hp) and 40 taper mills. The built-in casters make it easy to move for maintenance.

| Model | Flow | Pressure | Outlets | Tank | Options | Hydracell | Dimensions |
|---------|----------------------|----------|---------|------|---------|-----------|-----------------------|
| B-30/70 | 30 liters per minute | 70 bar | 1 | N/A | N/A | N/A | 0.79m x 0.86m x 0.69m |

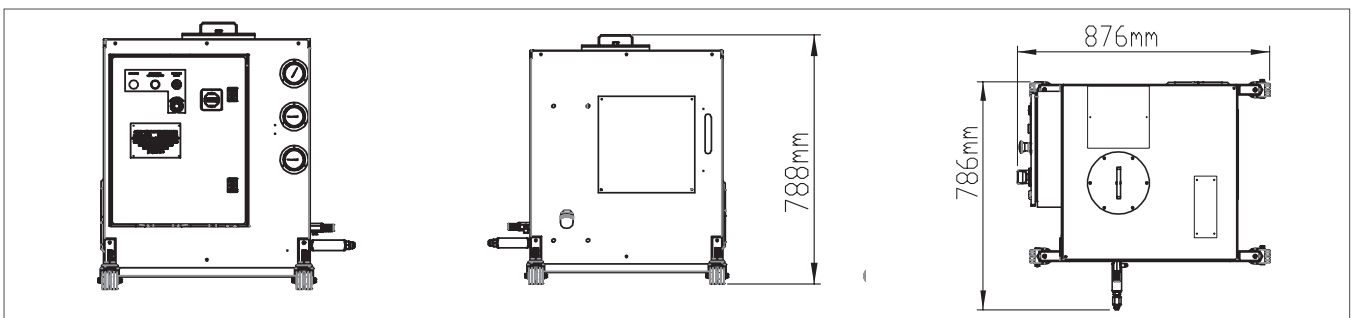

B-30/70H



CHIPBLASTER B-30/70H fixed rate, high pressure coolant system has a number of standard safety features, including integrated automatic overload protection, to safeguard the machine-tool, workpiece and tooling during unattended and lights-out production. In addition, maintenance-free cyclonic filtration to 2 microns enables lights-out 24/7 production. The included diaphragm style pump means this unit will stand up to even the most extreme of applications. These safety measures meet or exceed all international requirements. The built-in casters make it easy to move for maintenance.

| Model | Flow | Pressure | Outlets | Tank | Options | Hydracell | Dimensions |
|----------|----------------------|----------|---------|------------|-------------|-----------|-----------------------|
| B-30/70H | 30 liters per minute | 70 bar | 1 | 190 liters | Oil Skimmer | Included | 1.23m x 0.93m x 0.65m |

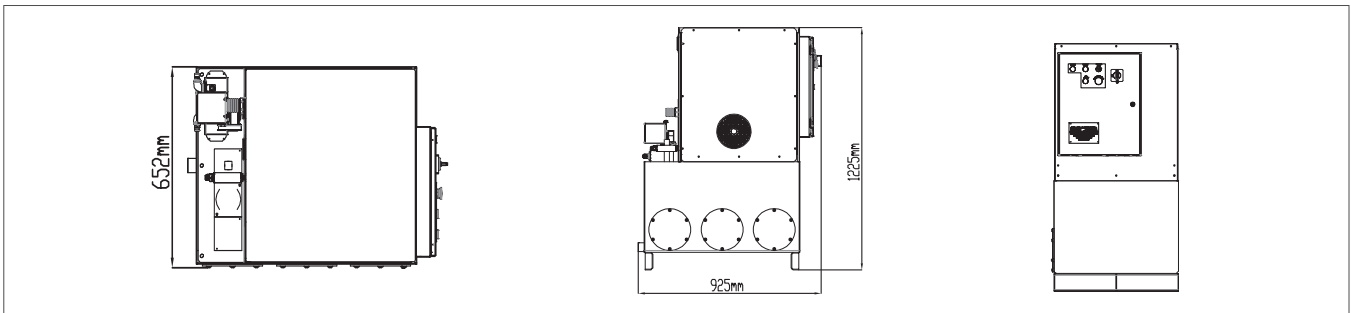

OIL REMOVAL SERIES

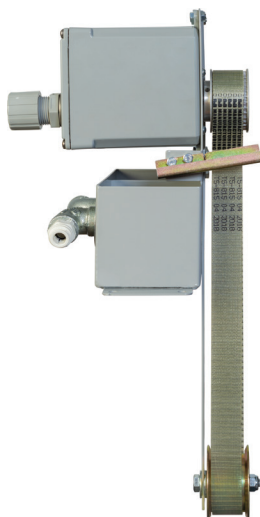

B-30/70H Option

CHIPBLASTER OS coolant skimmer removes tramp oils for extended coolant life and a healthier workplace.

| Model | Dimension |
|-------|---------------------------------|
| CB OS | Included in base unit footprint |



CHIPBLASTER ADDITIONAL ACCESSORIES

CHILLER SERIES



- 34,000 BTU
- Cooling capacity suits virtually all applications
- Optional heater for precise temperature control

| Model | Dimensions |
|-----------|---------------------------------|
| CC 34K | Included in base unit footprint |
| CC 34K SA | 0.92m x 0.88m x 1.24m |

FILTER SERIES



- Up to 100% filtering to 10 microns
- Up to 95% filtering to 5 microns
- Up to 50% filtering to 2 microns

| Model | Dimensions |
|----------|---------------------------------|
| CF-79 | Included in base unit footprint |
| CF-79 SA | 0.97m x 0.69m x 0.64m |

SLUDGE TANK

- Recommended to complement Chipblaster CF-79 cyclone filter. The Chipblaster sludge tank holds particulates outside of the machine-tool sump and is easy to access for cleaning.

| Model | Dimensions |
|-----------|-----------------------|
| CB ST 200 | 0.67m x 0.46m x 0.95m |

MIST COLLECTORS

| EMULSION OR OIL | | WS 2 250* | WS 2 500* | WS 2 1000 | WS 2 1500 | WS 2 2000 |
|--------------------------|---------------------|--------------|--------------|--------------|--------------|--------------|
| Technical specifications | | 50 Hz | 50 Hz | 50 Hz | 50 Hz | 50 Hz |
| Air flow | [m ³ /h] | 240 | 470 | 950 | 1450 | 1800 |
| Motor | [kW] | 0.24 | 0.37 | 0.75 | 1.5 | 2.2 |
| Static pressure | [Pa] | 470 | 610 | 950 | 1260 | 1720 |
| Weight | [kg] | 28 | 35 | 55 | 75 | 85 |
| Sound level | [dB(A)] | 62 | 65 | 71 | 74 | 76 |

YOUR ONE-STOP-SHOP FOR MACHINE-TOOL PERIPHERALS

LNS provides a full range of bar feeders, chip conveyors, coolant management systems and air filtration systems which is second to none on the market. We are known in the industry for the solid expertise we have gained over several decades in an exceptionally wide range of applications, our excellent customer service and technical support. This support is ensured by highly qualified technicians who are available at key locations throughout Europe.



LNS Europe
Route de Frinwillier
2534 Orvin
Switzerland

+41 32 358 02 00
LNS@LNS-europe.com
www.LNS-europe.com