

TECHNICAL DATA:

Workpiece diameter	2 - 250	mm
Grinding length max.	580	mm
Clamping length max.	1030	mm
Module	0.5 - 10	mm
Lead angle	+/- 50	°
Workpiece weight max.	250	kg
Grinding wheel drive	15	kW
Cutting speed max.	45	m/s
Relief frequency max.	10	Hz

Wheel diam. (spindle 17)	25 - 40	mm
Wheel width	6 - 13	mm
Wheel diam. (spindle 26)	35 - 50	mm
Wheel width	8 - 16	mm
Wheel diam. (spindle 32)	40 - 70	mm
Wheel width	10 - 20	mm
Wheel diam. (spindle 45)	55 - 100	mm
Wheel width	15 - 25	mm

(technical changes reserved)

PRODUCT INFORMATION

The universal CNC thread grinding machines in the **RG** series are particularly suitable for grinding worms, threaded spindles, ball screw spindles and thread rolling discs as well as hobs. The highly stable basic structure (machine body is made of polymer concrete) enables high productivity and optimum precision (basis: Reishauer thread grinding machine type RG500).

The use of the latest CNC dressing technology in combination with a powerful profile calculation software system allows for high flexibility and precision so that virtually all dressable profiles can be transferred with the highest degree of precision to the grinding wheel.

In the **-U version**, these machines are used for grinding single and multi-start gear worms (with standard profiles according to DIN such as ZI, ZK, ZA, ZN & ZC and for special profiles). Achievable accuracies are in the range 2 - 5 according to DIN 3962.

The **-HG version** allows grinding of threading tools (focus: cutting tap/forming tap (LH/RH)).

In the **-HW version**, the machine is used in particular for grinding hobs and similar workpieces. Hob qualities of AAA as per DIN 3968 can be achieved without difficulty. Workpieces made from HSS and - with the help of special equipment - carbide can be ground.

In the **-I version**, a special internal grinding attachment is used to grind internal threads. A variety of HF spindles are available for this purpose.

The machine is equipped with the latest drive and control technology (digital servo drives: Bosch-Rexroth or Siemens, axial and angle measurement systems: Heidenhain). Thanks to the workpiece-specific user interface by SMS (HMI), the CNC control system (Siemens 840D sl or Bosch Rexroth MTX) can easily be programmed by the operator in the dialogue system and allows for short setup times.

For series production, these machines can be equipped with an optional automatic loading system – adapted to the respective requirements.

Supported by:



on the basis of a decision
by the German Bundestag

Available options for RG500 / RG1000 / RG2000:

- Various dressing units
- Automatic loading system
- Relief support with linear motor (optional)
- Indexing unit

The machine can be equipped with max. 8 CNC axes:

Workpiece drive	(C-axis)
Workpiece slide	(Z-axis)
Grinding support	(X-axis)
Helix angle	(A-axis)
Dressing axis radial (optional)	(V-axis)
Dressing axis axial (optional)	(W-axis)
Cooling nozzle positioning	(U-axis)
Relief support (optional)	(X2-axis)

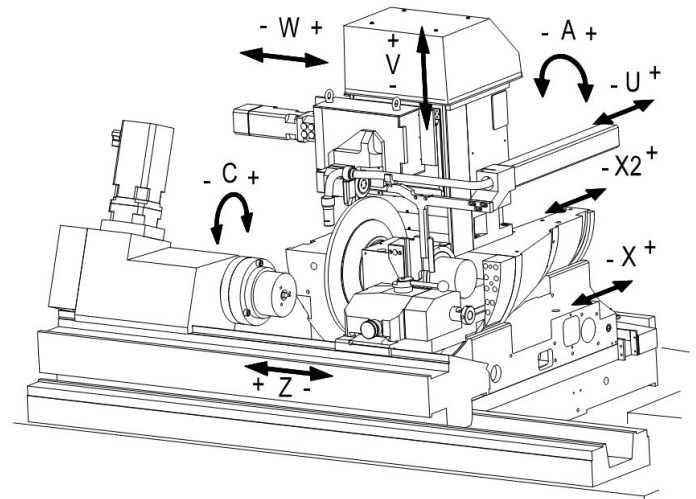

Machining example: Relief grinding of hob (steel)

Modul:	7,5 mm
Number of starts:	9
Length:	163 mm
Diameter:	120 mm
Number of gashes:	12
Cycle time:	28 min

